

EchoPilot FLS Transducer Installation

FLS Transducers

Professional or Standard?

The professional (Grey) transducer has a narrower beam, which gives a more accurate representation of the seabed. However, the Standard (Red) transducer can appear better, simply because it is collecting data from a wider seabed area.

A thick hull or one with a steep dead rise will usually require the Professional transducer as the bronze skin fitting has 75 mm (3") of useable thread whereas the Glass Filled Polypropylene skin fitting for the Standard transducer has 25 mm (1") of useable thread.

Transducer Cable Extension

The standard cable length is 12 metres, but this can be extended in multiples of 8 metres.

The transducer is of an active design, that is to say that it requires power from the display unit to operate its transmitter and receiver circuitry. This has the advantage of allowing greater cable runs than were possible with the old passive type of FLS transducer.

There is obviously a small, but additive loss of performance on any cable length of 20 metres or more. The maximum cable length possible does depend on the area that the vessel will be operating in. Hard seabeds and shallower maximum depths allow for longer cable runs.

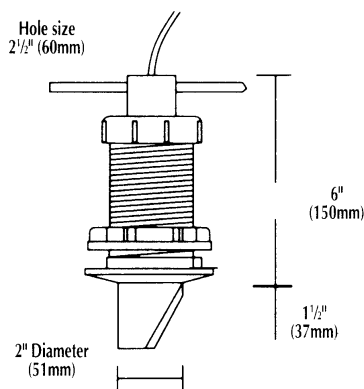

**Professional
Transducer**

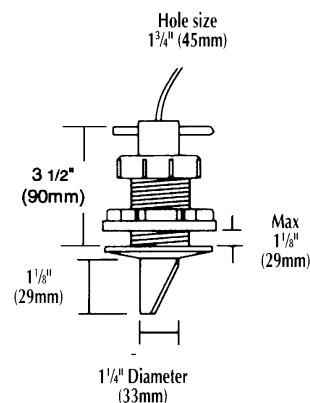

**Standard
Transducer**

Transducer Position

The choice of transducer position will have a major effect on final performance so please consider carefully all factors and if in any doubt, telephone the factory.

Motor Boats

- On a planing hull, fit as far aft as reasonably possible. On V drive and stern drive boats (inboard /outboard), typically fit just in front of the engine(s). On a shaft driven boat (not V drive), forward of the shaft log or stern gland, but behind the gearbox.
- Keep inboard of the spray rail if possible.
- If possible do not fit downstream of any other through hull fittings (for example intakes, log, toilet sea cocks, etc.).
- The transducer should ideally be vertical in both planes at displacement trim. If it leans forward, the seabed appears to creep up, and if it rakes aft too much surface clutter may show. Port/starboard heel will affect performance so avoid this if possible.
- Avoid the temptation to fit the transducer too far forward. The transducer may leave solid water when at speed, or when pitching. Also remember the transducer looks down as well as out, so when manoeuvring in confined waters you may wish to see there is water for the propellers and rudders.

Sailing Boats

- On a fin keeled boat, alongside the keel (perhaps 60 cm or 2 ft out) is often a well protected position (but **not** on a boat with a winged keel or a large bulb). Just forward of the keel is an alternative, but take care when hoisting the boat in a sling!
- Resist the temptation to fit the transducer too far forward. The transducer will come out of the water when pitching. Remember that the transducer looks out as well as down - you will need to see what is under your boat as well as what is ahead. When manoeuvring in confined spaces, you wish to know what is under the keel or rudder.
- For long keeled boats, choose the position with the minimum angle of deadrise (i.e. the flattest area), fit the transducer with a wedge shaped chock if necessary to make the transducer as near to vertical as possible with the boat upright.
- In all cases, ensure the body of the hull does not obscure the forward or side view up to and above the horizontal.

Fitting the Skin Fitting

A hole in the boat must be taken seriously! - If in doubt use an experienced shipwright.

- For the Standard **plastic** skin fitting - cut a 45 mm (1 ³/₄") diameter hole.
- For the Professional **bronze** skin fitting - cut a hole, 60 mm (2 ¹/₂") in diameter.
- Fit the skin fitting with reinforcing pads if needed or wedges if required to ensure the transducer is as near to vertical as possible (in fore **and** aft planes).
- Use plenty of underwater sealant, but take care to clean off the thread thoroughly afterwards.
- Secure with the nut on the inside. Do not use excessive force on the nut.
- If the vessel will be floated **before** the transducer is fitted, the blanking cap provided must be fitted to seal the skin fitting. (N.B. for our American customers, for "skin fitting" read "thru-hull fitting").

Fitting the Transducer

With care, this may be done afloat. However, if you have never done this before, please phone us first!

- If the vessel is afloat, place the FLS transducer close to hand near the skin fitting, remove the blanking cap and quickly!
- Place the transducer into the skin fitting, making sure that the **sharp** pointed end of the bronze handle is pointing **towards** the vessels **bow**. Using only your hand, screw down the securing nut onto the top of the skin fitting.
- Connect the plug of the transducer cable to the back of the instrument.

Safety

The transducer provided is designed to shear off (in the event of a severe impact), flush with the hull, leaving the solid epoxy filled portion in the through hull fitting, and thus poses no risk of water ingress.